

MULLION

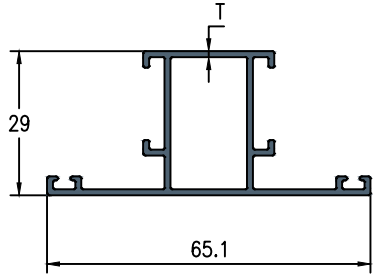

NO.	SECTION NO.	W	H	T	WEIGHT KG/12'
1	HD - 29100	65.10	29.00	1.20	2.000 - 2.200

OUTER FRAME

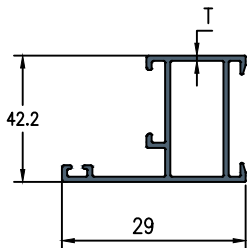

NO.	SECTION NO.	W	H	T	WEIGHT KG/12'
1	HD - 29110	29.00	42.20	1.20	1.600 - 1.800

SHUTTER

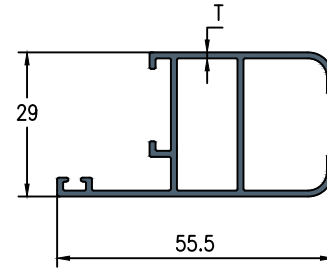

NO.	SECTION NO.	W	H	T	WEIGHT KG/12'
1	HD - 29105	55.50	29.00	1.20	2.000 - 2.200

CLIP

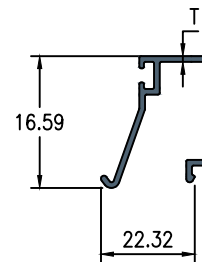

NO.	SECTION NO.	W	H	T	WEIGHT KG/12'
1	HD - 29115	22.32	16.59	1.00	0.650 - 0.750

FRAME

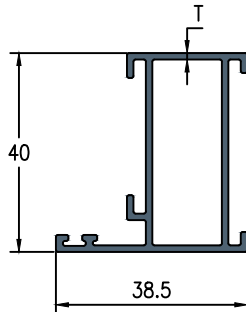

N0.	SECTION NO.	W	H	T	WEIGHT KG/12'
1	HD - 40000	38.50	40.00	1.30	2.000 - 2.200

CLIP

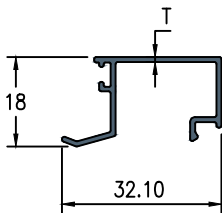

N0.	SECTION NO.	W	H	T	WEIGHT KG/12'
1	HD - 40020	32.10	18.00	1.00	0.750 - 0.850

SHUTTER

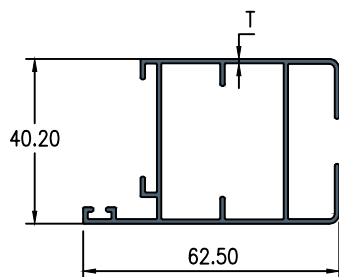

N0.	SECTION NO.	W	H	T	WEIGHT KG/12'
1	HD - 40005	62.50	40.20	1.05	2.600 - 2.800

MULLIAN

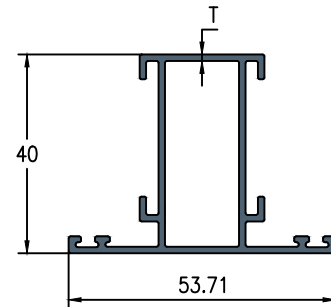

N0.	SECTION NO.	W	H	T	WEIGHT KG/12'
1	HD - 40010	53.71	40.00	1.30	2.300 - 2.500

BIG MULLIAN

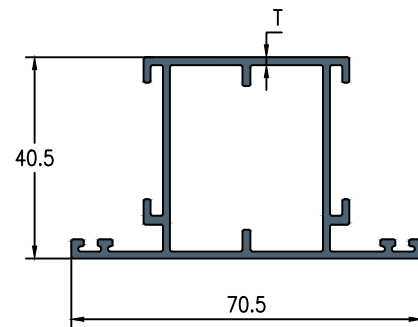

N0.	SECTION NO.	W	H	T	WEIGHT KG/12'
1	HD - 40030	70.50	40.50	1.40	3.200 - 3.600

SHUTTER

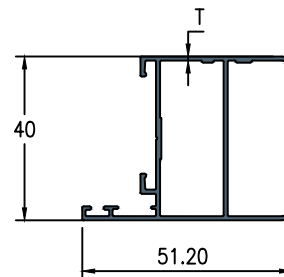

N0.	SECTION NO.	W	H	T	WEIGHT KG/12'
1	HD - 40015	51.20	40.00	1.00	2.200 - 2.500

2 IN 1 FRAME

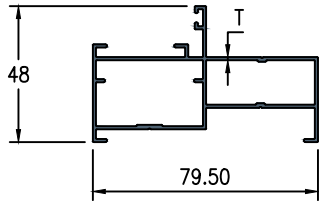

N0.	SECTION NO.	W	H	T	WEIGHT KG/12'
1	HD - 40035	79.50	48.00	1.10	3.300 - 3.600

2 IN 1 MIDDLE

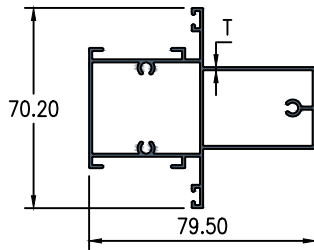

N0.	SECTION NO.	W	H	T	WEIGHT KG/12'
1	HD - 40045	79.50	70.20	1.10	4.000 - 4.400

3 IN 1 FRAME

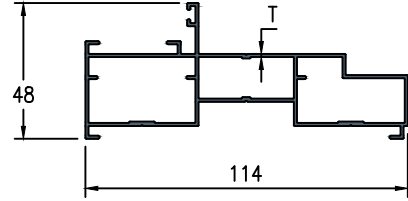

N0.	SECTION NO.	W	H	T	WEIGHT KG/12'
1	HD - 40040	114.00	48.00	1.10	4.400 - 4.800

3 IN 1 MIDDLE

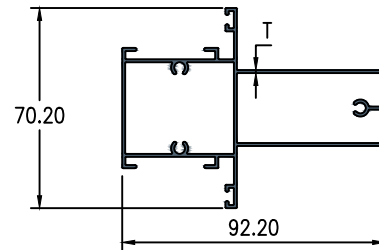

N0.	SECTION NO.	W	H	T	WEIGHT KG/12'
1	HD - 40050	92.20	70.20	1.03	4.000 - 4.400

SINGLE FRAME

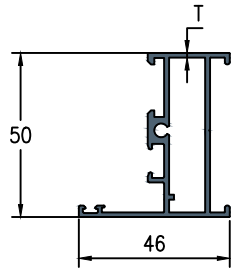

N0.	SECTION NO.	W	H	T	WEIGHT KG/12'
1	HD - 50010	46.00	50.00	1.25	2.900 - 3.200

BIG FRAME

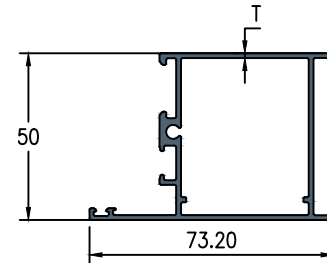

N0.	SECTION NO.	W	H	T	WEIGHT KG/12'
1	HD - 50015	73.20	50.00	1.45	3.700 - 4.000

SINGLE MULLION

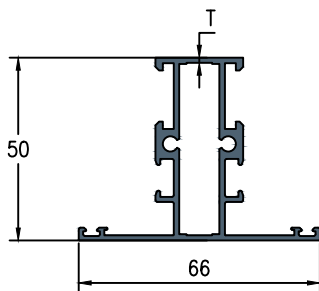

N0.	SECTION NO.	W	H	T	WEIGHT KG/12'
1	HD - 50020	66.00	50.00	1.50	3.600 - 3.900

MULLION

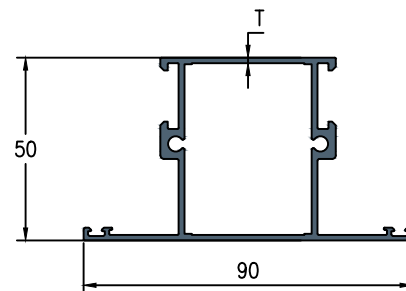

N0.	SECTION NO.	W	H	T	WEIGHT KG/12'
1	HD - 50025	90.00	50.00	1.50	4.300 - 4.700

DOOR SHUTTER

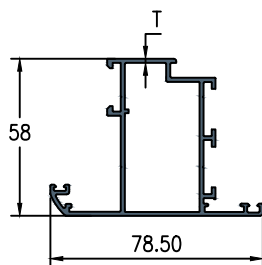

N0.	SECTION NO.	W	H	T	WEIGHT KG/12'
1	HD - 50000	78.50	58.00	1.25	4.000 - 4.400

OUTER SHUTTER

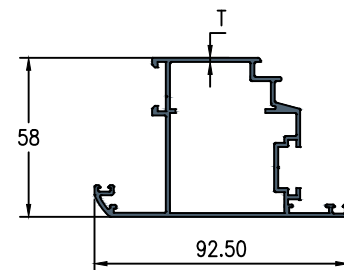

N0.	SECTION NO.	W	H	T	WEIGHT KG/12'
1	HD - 50005	92.50	58.00	1.50	4.700 - 5.100

FLYING MULLION

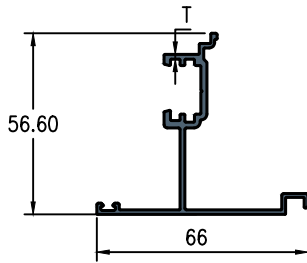

NO.	SECTION NO.	W	H	T	WEIGHT KG/12'
1	HD - 50030	66.00	56.60	1.50	2.500 - 2.700

REVERSE ADP

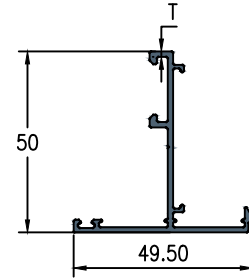

NO.	SECTION NO.	W	H	T	WEIGHT KG/12'
1	HD - 50035	49.50	50.00	1.50	1.800 - 2.000

DOOR BOTTOM

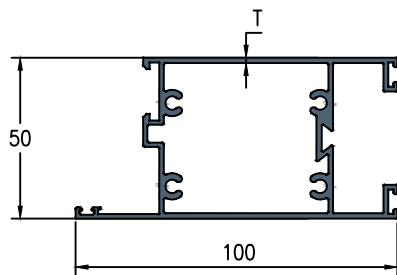

NO.	SECTION NO.	W	H	T	WEIGHT KG/12'
1	HD - 50060	100.00	50.00	1.50	6.000 - 6.500

COMBINATION FRAME

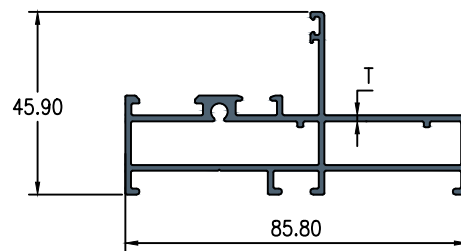

NO.	SECTION NO.	W	H	T	WEIGHT KG/12'
1	HD - 50065	85.80	45.90	1.40	4.300 - 4.700

INSIDE SHUTTER

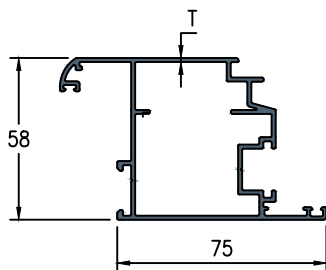

NO.	SECTION NO.	W	H	T	WEIGHT KG/12'
1	HD - 50055	75.00	58.00	1.45	5.000 - 5.500

DOOR BOTTOM ADP

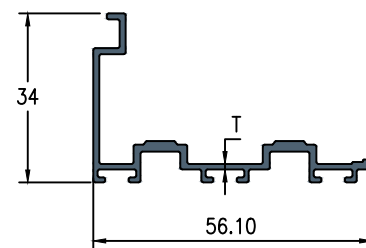

NO.	SECTION NO.	W	H	T	WEIGHT KG/12'
1	HD - 50070	56.10	34.00	1.10	1.600 - 1.800

CLIP SGU

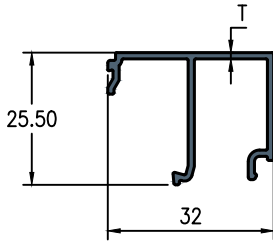

NO.	SECTION NO.	W	H	T	WEIGHT KG/12'
1	HD - 50050	32.00	25.50	1.20	1.100 - 1.300

CLIP DGU

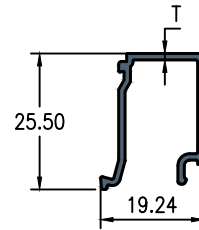

NO.	SECTION NO.	W	H	T	WEIGHT KG/12'
1	HD - 50040	19.24	25.50	1.20	0.800 - 0.900

GLASS CLIP

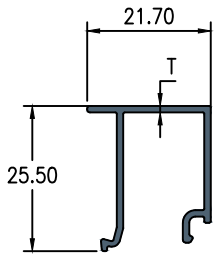

NO.	SECTION NO.	W	H	T	WEIGHT KG/12'
1	HD - 50045	21.70	25.50	1.13	0.800 - 1.000

FRAME

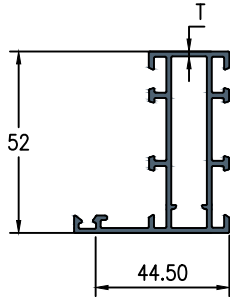

NO.	SECTION NO.	W	H	T	WEIGHT KG/12'
1	HD - 52000	52.00	44.50	1.40	3.100 - 3.400

SHUTTER

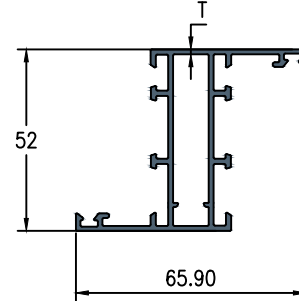

NO.	SECTION NO.	W	H	T	WEIGHT KG/12'
1	HD - 52005	65.90	52.00	1.40	3.500 - 3.800

MULLION

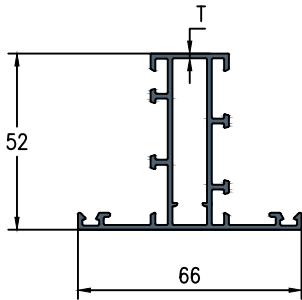

NO.	SECTION NO.	W	H	T	WEIGHT KG/12'
1	HD - 52010	66.00	52.00	1.40	3.500 - 3.800

BIG MULLION

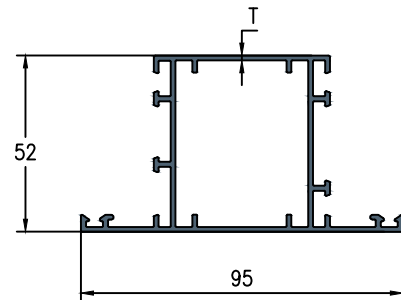

NO.	SECTION NO.	W	H	T	WEIGHT KG/12'
1	HD - 52015	95.00	52.00	1.40	4.500 - 4.900

SGU CLIP

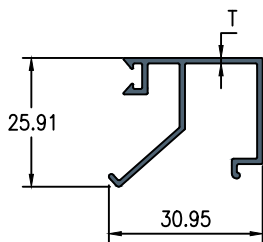

NO.	SECTION NO.	W	H	T	WEIGHT KG/12'
1	HD - 52020	30.95	25.91	1.10	1.050 - 1.200

DGU CLIP

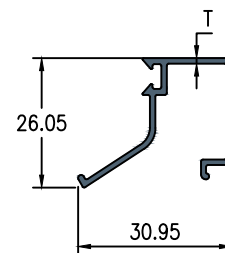

NO.	SECTION NO.	W	H	T	WEIGHT KG/12'
1	HD - 52025	30.95	26.05	1.10	0.900 - 1.100